

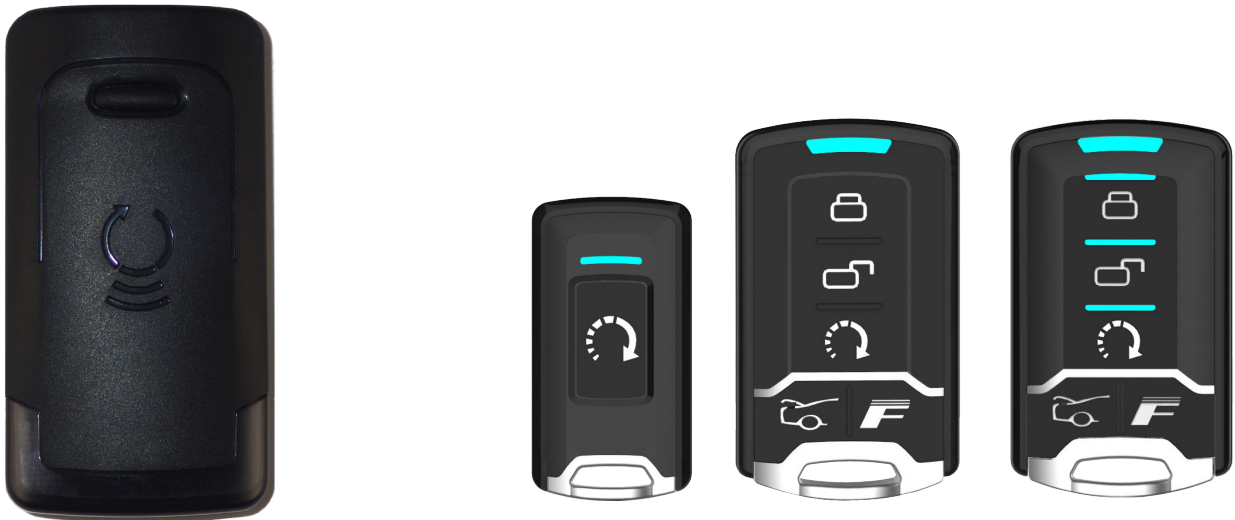

# CONNECTED

## COMPLETE INSTALLATION & PROGRAMMING GUIDE

### Digital RF Kit system



This system must be installed by a professional.

#### NOTICE

The manufacturer will accept no responsibility for any electrical damage resulting from improper installation of this product, be that either damage to the vehicle itself or to the installed device. This device must be installed by a certified technician. Please review the Installation Guide carefully before beginning any work.



# TABLE OF CONTENTS

Hardware Parts.....	3
ADS iDatastart HC or VW.....	4
ADS iDatastart BM - BZ.....	8
AKX Autokinetix or OEM.....	12
ADS-AL-CA.....	16
Firstech Compustar CM-7200.....	20
Firstech Compustar CM-6200.....	24
Directed DBALL 2.....	28
Directed 4X10, 5X10.....	32
Fortin Evo-All.....	36
Fortin Evo-One.....	40

# HARDWARE PARTS



**XTX-2000**



**RTX-2100**



**IVU-CAB-4W**



**RTX-1500**





**HRN-CRF-01**



**RTX-2500**



## REQUIRED PARTS FOR iDATASTART HC or VW INSTALLATION

<p>XTX-2000</p> 	<p>IVU-CAB-4W</p> 	<p>iDatastart HC or VW</p>  <p><b>ADS</b> AUTOMOTIVE DATA SOLUTIONS</p>	
---	---	---	--

### STEP 1. UPDATE YOUR ANTENNA

Connect your antenna to the ADS Weblink (ADS-USB) to update the antenna firmware to ensure that you have the latest firmware available.

- Go to [www.idatalink.com](http://www.idatalink.com) and click on “Flash your module” (See image #1)
- When your Connected XTX2000 antenna is detected it will offer the latest firmware available for your XTX2000.
- Select the most recent firmware available.
- Click “Flash!” (See image #2)



Image 1



Image 2

### STEP 2. CONFIGURE THE REMOTE STARTER

The ADS Weblink (ADS-USB) is required to properly configure the iDatastart HC or VW remote starter to accept the Connected RF kit. When flashing the iDatastart HC or VW remote starter, **please follow this procedure in order to configure correctly your remote starter.**

- Go to [www.idatalink.com](http://www.idatalink.com) and click on “Flash your module” (See image #1)
- When your iDatastart remote starter is detected it will offer you to go to the new Weblink page. Click on “CANCEL” before being re-directed. (See image #2) This will bring you to the older Weblink page.
- Choose vehicle Make, Model, Year, Trim (See image #3)
- Choose “CONNECTED RF KIT & Telematics”
- This selection should propose you to load a firmware starting with: “IDPP-XXX-XXX-XXX (X.X)” (See image #4)
- Click “Flash!” (See image #5)



Image 1

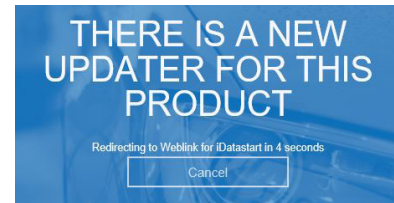

Image 2

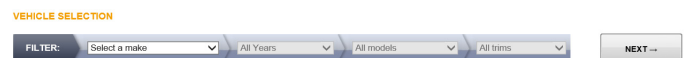

Image 3



Image 4



Image 5



# CONNECTED INSTALLATION, WIRING & PROGRAMMING GUIDE

## STEP 3. LEARN THE REMOTE STARTER

**BEFORE CONNECTING YOUR ANTENNA TO THE REMOTE STARTER** the remote starter **MUST** be learned to the vehicle. Please follow the remote starter installation manual on how to learn your remote starter to the vehicle that you are working on.

## STEP 4. CONNECT

Once the remote starter learning is completed, connect the RF Kit antenna by following the wiring guide as shown below.

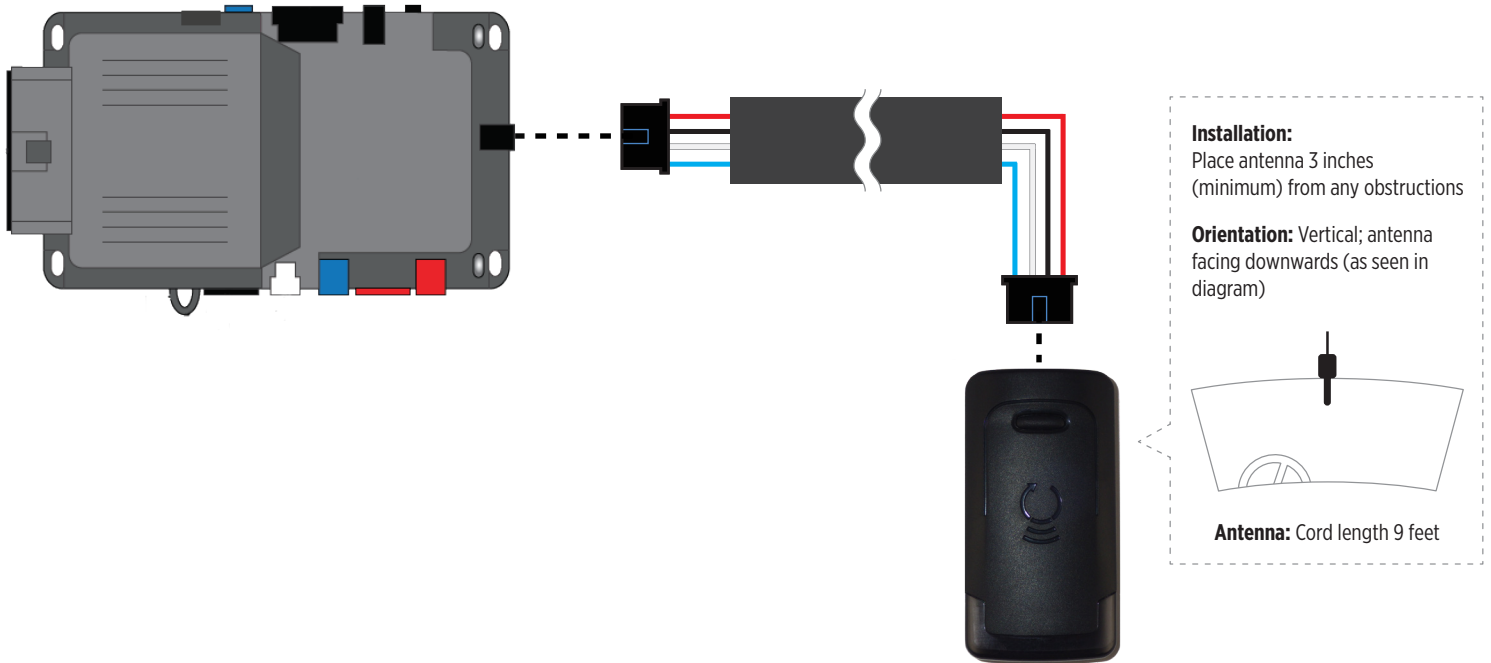

## STEP 5. LEARNING PROCEDURE

5A. AUTO-LEARNING PROCEDURE	5B. MANUAL LEARNING PROCEDURE
<p>NOTE: The transmitters and antenna included in this kit has already been pre-paired together at factory.</p> <ol style="list-style-type: none"> <li><b>PRESS AND HOLD</b> the programming button on the antenna while connecting the 4 pin connector - On power up there will be a quick Red and White LED blink.</li> <li>Then the Red LED will flash slowly, <b>RELEASE</b> the programming button</li> <li>The Red LED will turn solid for 2 seconds.</li> <li>Then the White LED will flash rapidly. This will initiate the Auto-learning procedure to detect which remote starter it's connected to.</li> <li>Once the remote starter model has been detected, the White LED will flash as indicated in the LED FLASH CHART below.</li> <li>If the auto-learning was succesful, proceed to Step 6.</li> </ol>	<ol style="list-style-type: none"> <li><b>PRESS AND HOLD</b> the programming button on the antenna while connecting the 4 pin connector - On power up there will be a quick Red and White LED blink.</li> <li>Then the Red LED will flashes slowly. Keep holding the programming button for a few seconds until the Red LED flashes rapidly, <b>RELEASE</b> the programming button</li> <li>The Red LED will turn solid for 2 seconds.</li> <li>Then the White LED will flash slowly. This will initiate the Manual Learning Procedure.</li> <li><b>Press and Release</b> the programming button on the antenna to make your selection as indicated below.</li> <li>Once the correct selection is made, <b>PRESS AND HOLD</b> the programming button until the White LED turns solid for 2 seconds.</li> </ol>

### LED FLASH CHART

- 1x flash = iDatastart HC - VW
- 2x flashes = Directed
- 3x flashes = Compustar Blade
- 4x flashes = Fortin - AKX - iDatastart BM, BZ - ADS-AL-CA
- 5x flashes = Unable to detect remote starter model. -- Please proceed to the "Manual Learning Procedure" in step 5B.



## STEP 6. TEST YOUR RF KIT

- a. Test all functions supported by your remote starter.
- b. If remote starter is reacting but the vehicle is not responding to a command, see your remote starter error code for diagnostics.
- c. If no reaction from the remote starter, please check your remote starter configurations or protocol selection.
- d. If it is still not working try programming the transmitters. Go to Step 7 below.

## STEP 7. PROGRAMMING TRANSMITTERS

NOTE: A maximum of 4x aftermarket transmitters can be programmed per system.

- a. Cycle ignition On/Off 5x times. (5x OFF/ON)
- b. The Red LED will turn On in the antenna.
- c. WHILE HOLDING THE TRANSMITTERS CLOSE TO THE ANTENNA (Max 1 foot away) Press and Release the Lock button on every transmitter that must be learned or "F" + Lock for 2nd Car operation.
- d. Cycle the ignition to OFF to exit programming mode.

## RESET PROCEDURE

NOTE: The reset procedure can be done at any time.



- a. PRESS AND HOLD the programming button on the Antenna while connecting the 4 pin connector.
- b. When the Red LED Flashes slowly, RELEASE the programming button.
- c. The Red LED will turn solid for 2 seconds.
- d. Reset completed



CONNECTED **INSTALLATION, WIRING & PROGRAMMING GUIDE**



REQUIRED PARTS FOR iDATASTART BM or BZ INSTALLATION

<p>XTX-2000</p> 	<p>IVU-CAB-4W</p> 	<p>iDatastart BM or BZ</p> 	
---	---	---	--

STEP 1. UPDATE YOUR ANTENNA

Connect your antenna to the ADS Weblink (ADS-USB) to update the antenna firmware to ensure that you have the latest firmware available.

- a. Go to [www.idatalink.com](http://www.idatalink.com) and click on “Flash your module” (See image #1)
- b. When your Connected XTX2000 antenna is detected it will offer the latest firmware available for your XTX2000.
- c. Select the most recent firmware available.
- d. Click “Flash!” (See image #2)



Image 1



Image 2

STEP 2. CONFIGURE THE REMOTE STARTER

The ADS Weblink (ADS-USB) is required to properly configure the iDatastart BM or BZ remote starter to accept the Connected RF kit. When flashing the iDatastart BM or BZ remote starter, **please follow this procedure in order to configure correctly your remote starter.**

- a. Go to [www.idatalink.com](http://www.idatalink.com) and click on “Flash your module” (See image #1)
- b. Choose vehicle Make, Model, Year, Trim (See image #2)
- c. Choose “COMPUSTAR RF KIT & Telematics”
- d. This selection should propose you to load a firmware starting with: “COM-XXX(XX) (X.X)” (See image #3)
- e. Click “Flash!” (See image #4)



Image 1

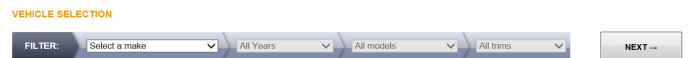

Image 2

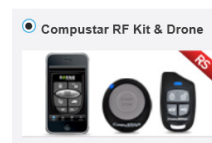

Image 3



Image 4

STEP 3. LEARN THE REMOTE STARTER

**BEFORE CONNECTING YOUR ANTENNA TO THE REMOTE STARTER** the remote starter **MUST** be learned to the vehicle. Please follow the remote starter installation manual on how to learn your remote starter to the vehicle that you are working on.





# CONNECTED INSTALLATION, WIRING & PROGRAMMING GUIDE

## STEP 4. CONNECT

Once the remote starter learning is completed, connect the RF Kit antenna by following the wiring guide as shown below.

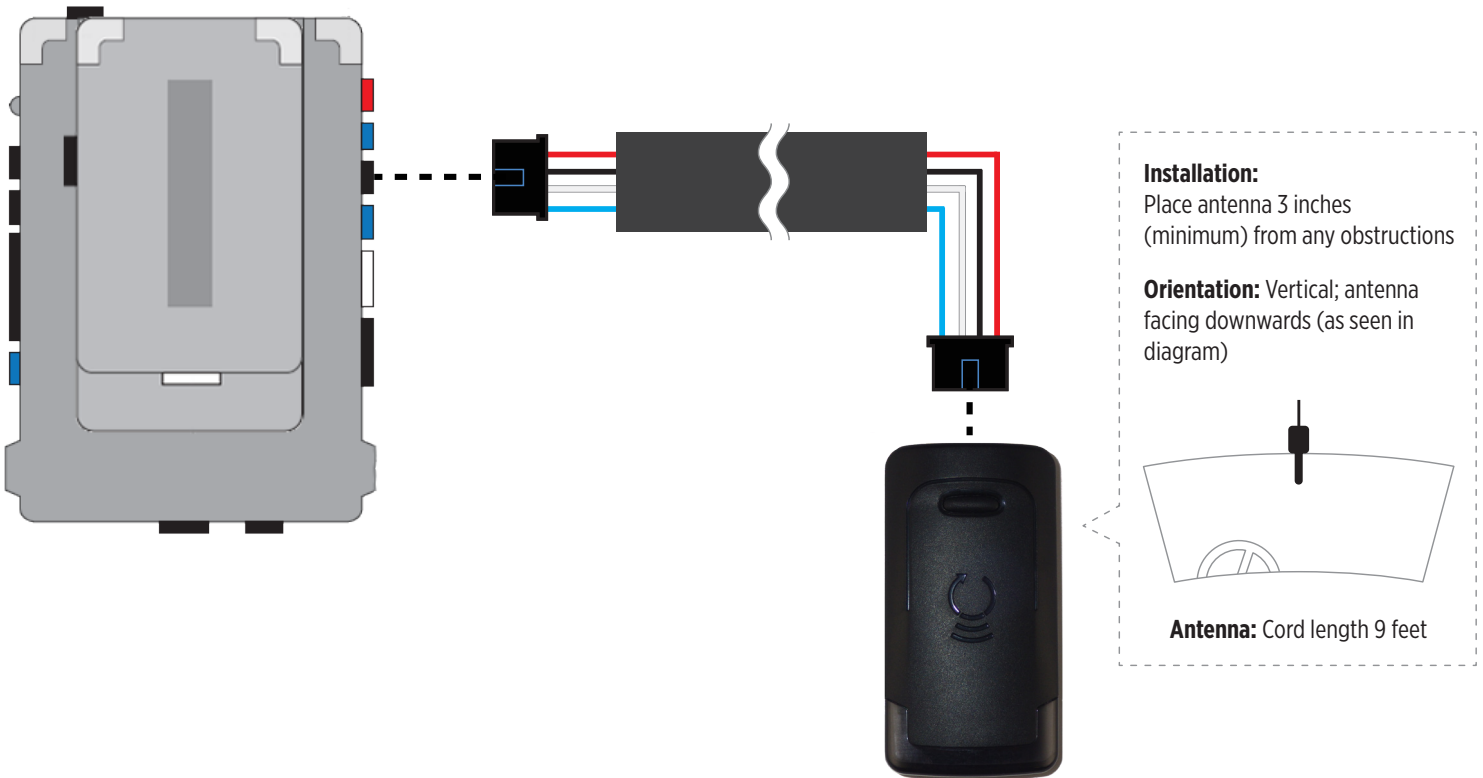

## STEP 5. LEARNING PROCEDURE

5A. AUTO-LEARNING PROCEDURE	5B. MANUAL LEARNING PROCEDURE
<p>NOTE: The transmitters and antenna included in this kit has already been pre-paired together at factory.</p> <ol style="list-style-type: none"> <li><b>PRESS AND HOLD</b> the programming button on the antenna while connecting the 4 pin connector - On power up there will be a quick Red and White LED blink.</li> <li>Then the Red LED will flash slowly, <b>RELEASE</b> the programming button</li> <li>The Red LED will turn solid for 2 seconds.</li> <li>Then the White LED will flash rapidly. This will initiate the Auto-learning procedure to detect which remote starter it's connected to.</li> <li>Once the remote starter model has been detected, the White LED will flash as indicated in the LED FLASH CHART below.</li> <li>If the auto-learning was succesful, proceed to Step 6.</li> </ol>	<ol style="list-style-type: none"> <li><b>PRESS AND HOLD</b> the programming button on the antenna while connecting the 4 pin connector - On power up there will be a quick Red and White LED blink.</li> <li>Then the Red LED will flashes slowly. Keep holding the programming button for a few seconds until the Red LED flashes rapidly, <b>RELEASE</b> the programming button</li> <li>The Red LED will turn solid for 2 seconds.</li> <li>Then the White LED will flash slowly. This will initiate the Manual Learning Procedure.</li> <li><b>Press and Release</b> the programming button on the antenna to make your selection as indicated below.</li> <li>Once the correct selection is made, <b>PRESS AND HOLD</b> the programming button until the White LED turns solid for 2 seconds.</li> </ol>
<p><b>LED FLASH CHART</b></p>	
<ol style="list-style-type: none"> <li>1x flash = iDatastart HC - VW</li> <li>2x flashes = Directed</li> <li>3x flashes = Compustar Blade</li> <li><b>4x flashes = Fortin - AKX - iDatastart BM, BZ - ADS-AL-CA</b></li> <li>5x flashes = Unable to detect remote starter model. -- Please proceed to the "Manual Learning Procedure" in step 5B.</li> </ol>	



## STEP 6. PROGRAMMING TRANSMITTERS

NOTE: A maximum of 4x aftermarket transmitters can be programmed per system.

- a. Cycle ignition On/Off 5x times. (5x OFF/ON)
- b. The Red LED will turn On in the antenna.
- c. WHILE HOLDING THE TRANSMITTERS CLOSE TO THE ANTENNA (Max 1 foot away) Press and Release the Lock button on every transmitter that must be learned or “F” + Lock for 2nd Car operation.
- d. Cycle the ignition to OFF to exit programming mode.

## STEP 7. TEST YOUR RF KIT

- a. Test all functions supported by your remote starter.
- b. If remote starter is reacting but the vehicle is not responding to a command, see your remote starter error code for diagnostics.
- c. If no reaction from the remote starter, please check your remote starter configurations or protocol selection.
- d. If it is still not working try programming the transmitters. Go to Step 6 above.

## RESET PROCEDURE



NOTE: The reset procedure can be done at any time.

- a. PRESS AND HOLD the programming button on the Antenna while connecting the 4 pin connector.
- b. When the Red LED Flashes slowly, RELEASE the programming button.
- c. The Red LED will turn solid for 2 seconds.
- d. Reset completed





REQUIRED PARTS FOR AKX or OEM INSTALLATION

<p>XTX-2000</p> 	<p>IVU-CAB-4W</p> 	<p>AKX or OEM</p> 	
---	---	--	--

STEP 1. UPDATE YOUR ANTENNA

Connect your antenna to the ADS Weblink (ADS-USB) to update the antenna firmware to ensure that you have the latest firmware available.

- a. Go to [www.idatalink.com](http://www.idatalink.com) and click on “Flash your module” (See image #1)
- b. When your Connected XTX2000 antenna is detected it will offer the latest firmware available for your XTX2000.
- c. Select the most recent firmware available.
- d. Click “Flash!” (See image #2)



Image 1



Image 2

STEP 2. CONFIGURE THE REMOTE STARTER

The ADS Weblink (ADS-USB) is required to properly configure the AKX or OEM remote starter to accept the Connected RF kit. When flashing the AKX or OEM remote starter, **please follow this procedure in order to configure correctly your remote starter.**

- a. Go to [www.idatalink.com](http://www.idatalink.com) and click on “Flash your module” (See image #1)
- b. Choose vehicle Make, Model, Year, Trim (See image #2)
- c. Choose “CONNECTED RF KIT & Telematics”
- d. This selection should propose you to load a firmware starting with: “AKXM-XX(RS)-XXX (X.X)” (See image #3)
- e. Click “Flash!” (See image #4)



Image 1

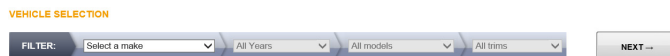

Image 2

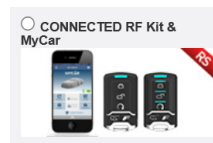

Image 3



Image 4

STEP 3. LEARN THE REMOTE STARTER

**BEFORE CONNECTING YOUR ANTENNA TO THE REMOTE STARTER** the remote starter **MUST** be learned to the vehicle. Please follow the remote starter installation manual on how to learn your remote starter to the vehicle that you are working on.



# CONNECTED INSTALLATION, WIRING & PROGRAMMING GUIDE

## STEP 4. CONNECT

Once the remote starter learning is completed, connect the RF Kit antenna by following the wiring guide as shown below.

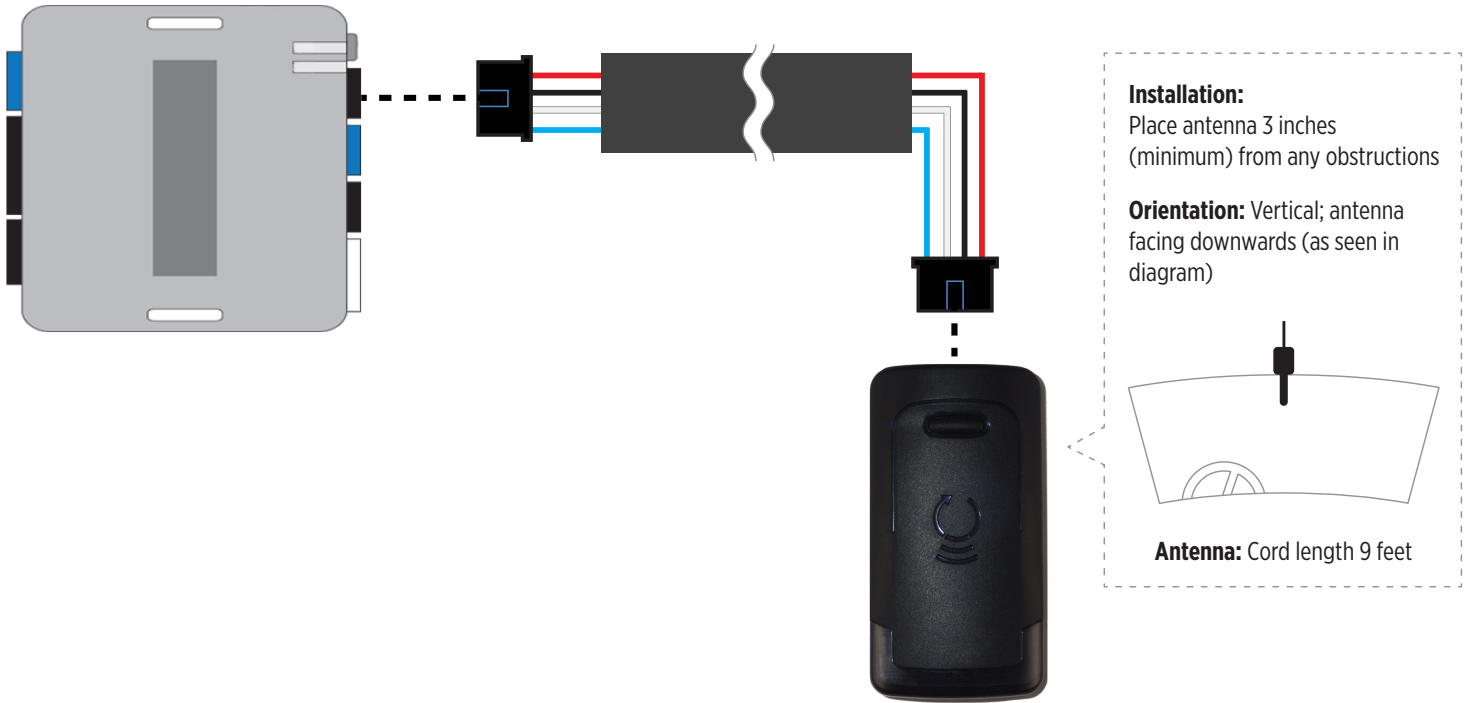

## STEP 5. LEARNING PROCEDURE

5A. AUTO-LEARNING PROCEDURE	5B. MANUAL LEARNING PROCEDURE
<p>NOTE: The transmitters and antenna included in this kit has already been pre-paired together at factory.</p> <ol style="list-style-type: none"> <li><b>PRESS AND HOLD</b> the programming button on the antenna while connecting the 4 pin connector - On power up there will be a quick Red and White LED blink.</li> <li>Then the Red LED will flash slowly, <b>RELEASE</b> the programming button</li> <li>The Red LED will turn solid for 2 seconds.</li> <li>Then the White LED will flash rapidly. This will initiate the Auto-learning procedure to detect which remote starter it's connected to.</li> <li>Once the remote starter model has been detected, the White LED will flash as indicated in the LED FLASH CHART below.</li> <li>If the auto-learning was succesful, proceed to Step 6.</li> </ol>	<ol style="list-style-type: none"> <li><b>PRESS AND HOLD</b> the programming button on the antenna while connecting the 4 pin connector - On power up there will be a quick Red and White LED blink.</li> <li>Then the Red LED will flashes slowly. Keep holding the programming button for a few seconds until the Red LED flashes rapidly, <b>RELEASE</b> the programming button</li> <li>The Red LED will turn solid for 2 seconds.</li> <li>Then the White LED will flash slowly. This will initiate the Manual Learning Procedure.</li> <li><b>Press and Release</b> the programming button on the antenna to make your selection as indicated below.</li> <li>Once the correct selection is made, <b>PRESS AND HOLD</b> the programming button until the White LED turns solid for 2 seconds.</li> </ol>

### LED FLASH CHART

- 1x flash = iDatastart HC - VW
- 2x flashes = Directed
- 3x flashes = Compustar Blade
- 4x flashes = Fortin - AKX - iDatastart BM, BZ - ADS-AL-CA**
- 5x flashes = Unable to detect remote starter model. -- Please proceed to the "Manual Learning Procedure" in step 5B.



## STEP 6. PROGRAMMING TRANSMITTERS

NOTE: A maximum of 4x aftermarket transmitters can be programmed per system.

- a. Cycle ignition On/Off 5x times. (5x OFF/ON)
- b. The Red LED will turn On in the antenna.
- c. WHILE HOLDING THE TRANSMITTERS CLOSE TO THE ANTENNA (Max 1 foot away) Press and Release the Lock button on every transmitter that must be learned or "F" + Lock for 2nd Car operation.
- d. Cycle the ignition to OFF to exit programming mode.

## STEP 7. TEST YOUR RF KIT

- a. Test all functions supported by your remote starter.
- b. If remote starter is reacting but the vehicle is not responding to a command, see your remote starter error code for diagnostics.
- c. If no reaction from the remote starter, please check your remote starter configurations or protocol selection.
- d. If it is still not working try programming the transmitters. Go to Step 6 above.

## RESET PROCEDURE



NOTE: The reset procedure can be done at any time.

- a. PRESS AND HOLD the programming button on the Antenna while connecting the 4 pin connector.
- b. When the Red LED Flashes slowly, RELEASE the programming button.
- c. The Red LED will turn solid for 2 seconds.
- d. Reset completed programming transmitters





REQUIRED PARTS FOR ADS-AL-CA INSTALLATION

<p>XTX-2000</p> 	<p>IVU-CAB-4W</p> 	<p>ADS-AL-CA</p> 	
---	---	---	--

STEP 1. UPDATE YOUR ANTENNA

Connect your antenna to the ADS Weblink (ADS-USB) to update the antenna firmware to ensure that you have the latest firmware available.

- a. Go to [www.idatalink.com](http://www.idatalink.com) and click on “Flash your module” (See image #1)
- b. When your Connected XTX2000 antenna is detected it will offer the latest firmware available for your XTX2000.
- c. Select the most recent firmware available.
- d. Click “Flash!” (See image #2)



Image 1



Image 2

STEP 2. CONFIGURE THE REMOTE STARTER

The ADS Weblink (ADS-USB) is required to properly configure the ADS-AL-CA remote starter to accept the Connected RF kit. When flashing the ADS-AL-CA remote starter, **please follow this procedure in order to configure correctly your remote starter.**

- a. Go to [www.idatalink.com](http://www.idatalink.com) and click on “Flash your module” (See image #1)
- b. Choose vehicle Make, Model, Year, Trim (See image #2)
- c. Choose “COMPUSTAR RF KIT & Telematics”
- d. This selection should propose you to load a firmware starting with: “COM-XXX(XX) (X.X)” (See image #3)
- e. Click “Flash!” (See image #4)



Image 1



Image 2



Image 3



Image 4

STEP 3. LEARN THE REMOTE STARTER

**BEFORE CONNECTING YOUR ANTENNA TO THE REMOTE STARTER** the remote starter **MUST** be learned to the vehicle. Please follow the remote starter installation manual on how to learn your remote starter to the vehicle that you are working on.





# CONNECTED INSTALLATION, WIRING & PROGRAMMING GUIDE

## STEP 4. CONNECT

Once the remote starter learning is completed, connect the RF Kit antenna by following the wiring guide as shown below. Connect a fused power and ground wire as shown on the diagram below in order to feed power to the ADS-AL-CA and the XTX-2000.

**IMPORTANT : Strip the end of the IVU-CAB-4W data cable and connect a 10Kohm resistor between the Red power wire and the Blue Data wire. This modification is required in order to get 2way communication.**

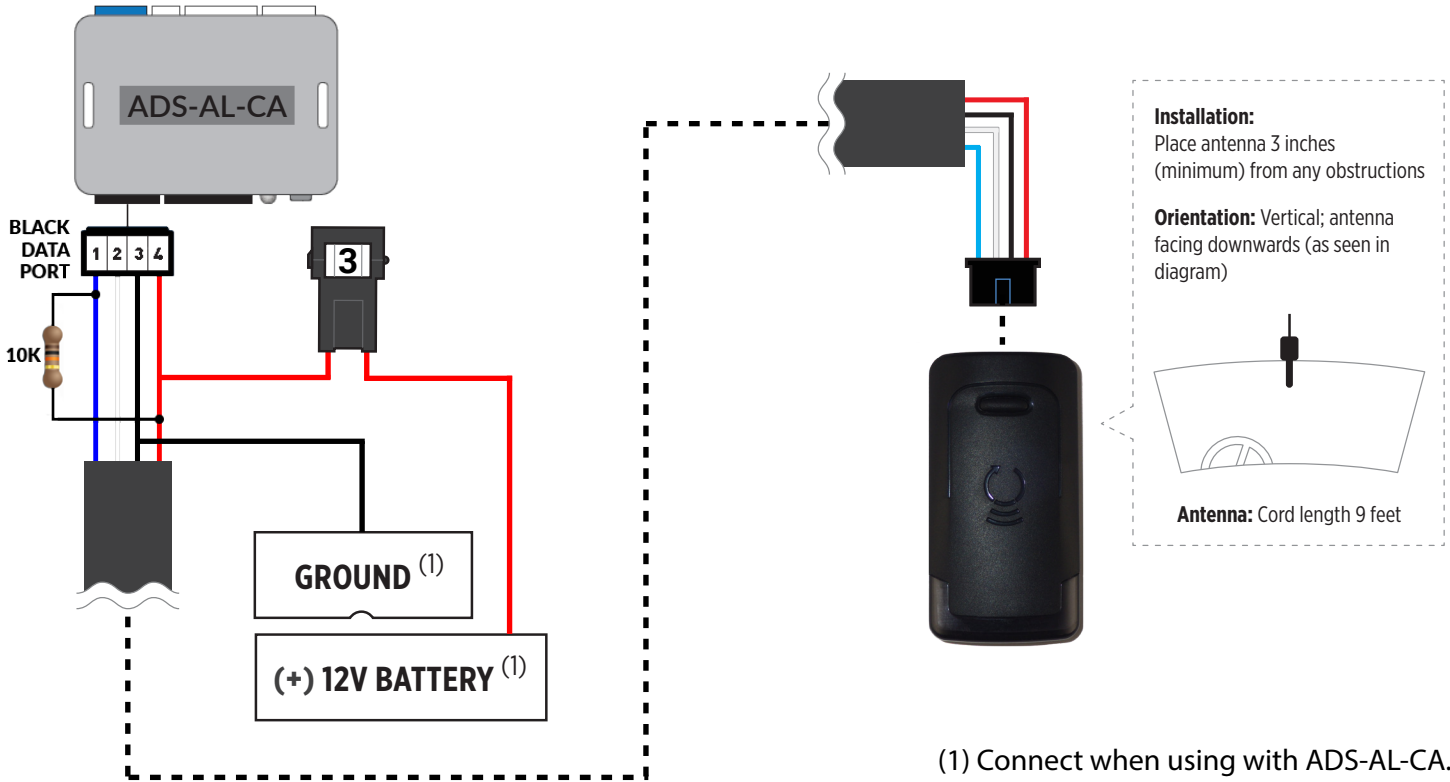



## STEP 5. LEARNING PROCEDURE

5A. AUTO-LEARNING PROCEDURE	5B. MANUAL LEARNING PROCEDURE
<p>NOTE: The transmitters and antenna included in this kit has already been pre-paired together at factory.</p> <ol style="list-style-type: none"> <li><b>PRESS AND HOLD</b> the programming button on the antenna while connecting the 4 pin connector - On power up there will be a quick Red and White LED blink.</li> <li>Then the Red LED will flash slowly, <b>RELEASE</b> the programming button</li> <li>The Red LED will turn solid for 2 seconds.</li> <li>Then the White LED will flash rapidly. This will initiate the Auto-learning procedure to detect which remote starter it's connected to.</li> <li>Once the remote starter model has been detected, the White LED will flash as indicated in the LED FLASH CHART below.</li> <li>If the auto-learning was succesful, proceed to Step 6.</li> </ol>	<ol style="list-style-type: none"> <li><b>PRESS AND HOLD</b> the programming button on the antenna while connecting the 4 pin connector - On power up there will be a quick Red and White LED blink.</li> <li>Then the Red LED will flashes slowly. Keep holding the programming button for a few seconds until the Red LED flashes rapidly, <b>RELEASE</b> the programming button</li> <li>The Red LED will turn solid for 2 seconds.</li> <li>Then the White LED will flash slowly. This will initiate the Manual Learning Procedure.</li> <li><b>Press and Release</b> the programming button on the antenna to make your selection as indicated below.</li> <li>Once the correct selection is made, <b>PRESS AND HOLD</b> the programming button until the White LED turns solid for 2 seconds.</li> </ol>
<b>LED FLASH CHART</b>	
<ol style="list-style-type: none"> <li>1x flash = iDatastart HC - VW</li> <li>2x flashes = Directed</li> <li>3x flashes = Compustar Blade</li> <li><b>4x flashes = Fortin - AKX - iDatastart BM, BZ - ADS-AL-CA</b></li> <li>5x flashes = Unable to detect remote starter model. -- Please proceed to the "Manual Learning Procedure" in step 5B.</li> </ol>	

## STEP 6. PROGRAMMING TRANSMITTERS

NOTE: A maximum of 4x aftermarket transmitters can be programmed per system.

- Cycle ignition On/Off 5x times. (5x OFF/ON)
- The Red LED will turn On in the antenna.
- WHILE HOLDING THE TRANSMITTERS CLOSE TO THE ANTENNA (Max 1 foot away) Press and Release the Lock button on every transmitter that must be learned or "F" + Lock for 2nd Car operation.
- Cycle the ignition to OFF to exit programming mode.

## STEP 7. TEST YOUR RF KIT

- Test all functions supported by your remote starter.
- If remote starter is reacting but the vehicle is not responding to a command, see your remote starter error code for diagnostics.
- If no reaction from the remote starter, please check your remote starter configurations or protocol selection.
- If it is still not working try programming the transmitters. Go to Step 6 above.

## RESET PROCEDURE





NOTE: The reset procedure can be done at any time.

- PRESS AND HOLD** the programming button on the Antenna while connecting the 4 pin connector.
- When the Red LED Flashes slowly, **RELEASE** the programming button.
- The Red LED will turn solid for 2 seconds.
- Reset completed



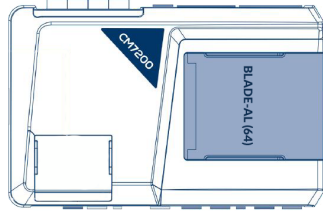

## REQUIRED PARTS FOR ADS-AL-CA INSTALLATION

<p>XTX-2000</p> 	<p>IVU-CAB-4W</p> 	<p>COMPUSTAR CM7200</p> 	<p>BLADE-AL (64)</p> 
---	---	--	--

### STEP 1. UPDATE YOUR ANTENNA

Connect your antenna to the ADS Weblink (ADS-USB) to update the antenna firmware to ensure that you have the latest firmware available.

- Go to [www.idatalink.com](http://www.idatalink.com) and click on “Flash your module” (See image #1)
- When your Connected XTX2000 antenna is detected it will offer the latest firmware available for your XTX2000.
- Select the most recent firmware available.
- Click “Flash!” (See image #2)



Image 1



Image 2

### STEP 2. CONFIGURE THE REMOTE STARTER

The ADS Weblink (ADS-USB) is required to properly configure the CM-7200 remote starter to accept the Connected RF kit. When flashing the CM-7200 remote starter, **please follow this procedure in order to configure correctly your remote starter.**

- Go to [www.idatalink.com](http://www.idatalink.com) and click on “Flash your module” (See image #1)
- Under the ADS-BLADE AL tab, Choose vehicle Make, Model, Year, Trim (See image #2)
- Click “Flash!” (See image #3)
- Once done click on the Remote Starter tab and click on “Flash my starter” in order to update the remote starter firmware.
- Click “Flash!” (See image #3)



Image 1

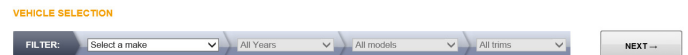

Image 2



Image 3

### STEP 3. LEARN THE REMOTE STARTER

**BEFORE CONNECTING YOUR ANTENNA TO THE REMOTE STARTER** the remote starter **MUST** be learned to the vehicle. Please follow the remote starter installation manual on how to learn your remote starter to the vehicle that you are working on.



# CONNECTED INSTALLATION, WIRING & PROGRAMMING GUIDE

## STEP 4. CONNECT

Once the remote starter learning is completed, connect the RF Kit antenna by following the wiring guide as shown below.

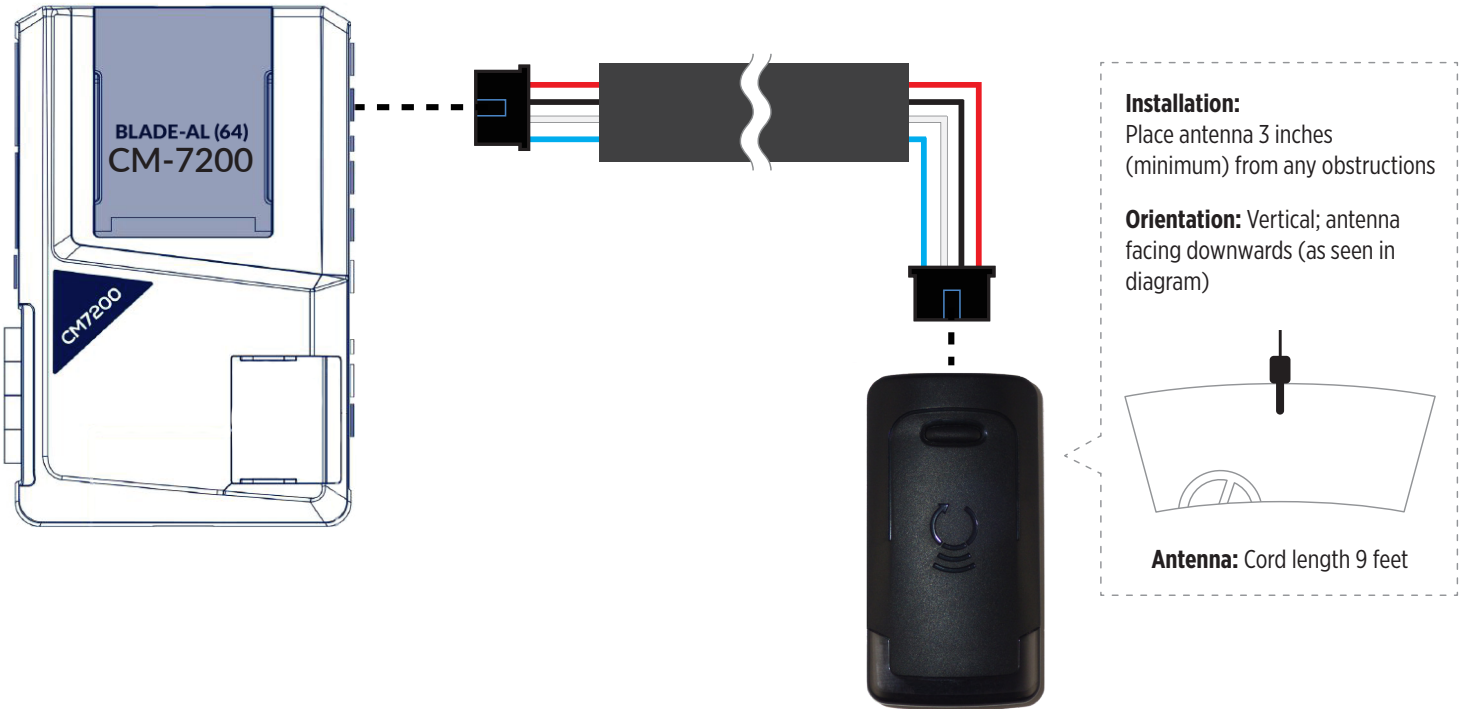

## STEP 5. LEARNING PROCEDURE

5A. AUTO-LEARNING PROCEDURE	5B. MANUAL LEARNING PROCEDURE
<p>NOTE: The transmitters and antenna included in this kit has already been pre-paired together at factory.</p> <ol style="list-style-type: none"> <li><b>PRESS AND HOLD</b> the programming button on the antenna while connecting the 4 pin connector - On power up there will be a quick Red and White LED blink.</li> <li>Then the Red LED will flash slowly, <b>RELEASE</b> the programming button</li> <li>The Red LED will turn solid for 2 seconds.</li> <li>Then the White LED will flash rapidly. This will initiate the Auto-learning procedure to detect which remote starter it's connected to.</li> <li>Once the remote starter model has been detected, the White LED will flash as indicated in the LED FLASH CHART below.</li> <li>If the auto-learning was succesful, proceed to Step 6.</li> </ol>	<ol style="list-style-type: none"> <li><b>PRESS AND HOLD</b> the programming button on the antenna while connecting the 4 pin connector - On power up there will be a quick Red and White LED blink.</li> <li>Then the Red LED will flashes slowly. Keep holding the programming button for a few seconds until the Red LED flashes rapidly, <b>RELEASE</b> the programming button</li> <li>The Red LED will turn solid for 2 seconds.</li> <li>Then the White LED will flash slowly. This will initiate the Manual Learning Procedure.</li> <li><b>Press and Release</b> the programming button on the antenna to make your selection as indicated below.</li> <li>Once the correct selection is made, <b>PRESS AND HOLD</b> the programming button until the White LED turns solid for 2 seconds.</li> </ol>

### LED FLASH CHART

- 1x flash = iDatastart HC - VW
- 2x flashes = Directed
- 3x flashes = Compustar Blade**
- 4x flashes = Fortin - AKX - iDatastart BM, BZ - ADS-AL-CA
- 5x flashes = Unable to detect remote starter model. -- Please proceed to the "Manual Learning Procedure" in step 5B.



## STEP 6. TEST YOUR RF KIT

- a. Test all functions supported by your remote starter.
- b. If remote starter is reacting but the vehicle is not responding to a command, see your remote starter error code for diagnostics.
- c. If no reaction from the remote starter, please check your remote starter configurations or protocol selection.
- d. If it is still not working try programming the transmitters. Go to Step 7 below.

## STEP 7. PROGRAMMING TRANSMITTERS

NOTE: A maximum of 4x aftermarket transmitters can be programmed per system.

- a. Cycle ignition On/Off 5x times. (5x OFF/ON)
- b. The Red LED will turn On in the antenna.
- c. WHILE HOLDING THE TRANSMITTERS CLOSE TO THE ANTENNA (Max 1 foot away) Press and Release the Lock button on every transmitter that must be learned or "F" + Lock for 2nd Car operation.
- d. Cycle the ignition to OFF to exit programming mode.

## RESET PROCEDURE





NOTE: The reset procedure can be done at any time.

- a. PRESS AND HOLD the programming button on the Antenna while connecting the 4 pin connector.
- b. When the Red LED Flashes slowly, RELEASE the programming button.
- c. The Red LED will turn solid for 2 seconds.
- d. Reset completed



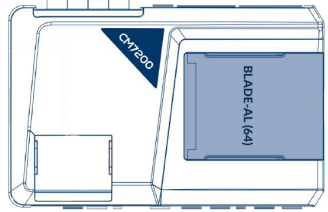

## REQUIRED PARTS FOR ADS-AL-CA INSTALLATION

<p>XTX-2000</p> 	<p>IVU-CAB-4W</p> 	<p>COMPUSTAR CM6200</p> 	<p>BLADE-AL (64)</p> 
---	---	--	--

### STEP 1. UPDATE YOUR ANTENNA

Connect your antenna to the ADS Weblink (ADS-USB) to update the antenna firmware to ensure that you have the latest firmware available.

- Go to [www.idatalink.com](http://www.idatalink.com) and click on “Flash your module” (See image #1)
- When your Connected XTX2000 antenna is detected it will offer the latest firmware available for your XTX2000.
- Select the most recent firmware available.
- Click “Flash!” (See image #2)



Image 1



Image 2

### STEP 2. CONFIGURE THE REMOTE STARTER

The ADS Weblink (ADS-USB) is required to properly configure the CM-6200 remote starter to accept the Connected RF kit. When flashing the CM-6200 remote starter, **please follow this procedure in order to configure correctly your remote starter.**

- Go to [www.idatalink.com](http://www.idatalink.com) and click on “Flash your module” (See image #1)
- Under the ADS-BLADE AL tab, Choose vehicle Make, Model, Year, Trim (See image #2)
- Click “Flash!” (See image #3)
- Once done click on the Remote Starter tab and click on “Flash my starter” in order to update the remote starter firmware.
- Click “Flash!” (See image #3)



Image 1



Image 2



Image 3

### STEP 3. LEARN THE REMOTE STARTER

**BEFORE CONNECTING YOUR ANTENNA TO THE REMOTE STARTER** the remote starter **MUST** be learned to the vehicle. Please follow the remote starter installation manual on how to learn your remote starter to the vehicle that you are working on.





# CONNECTED INSTALLATION, WIRING & PROGRAMMING GUIDE

## STEP 4. CONNECT

Once the remote starter learning is completed, connect the RF Kit antenna by following the wiring guide as shown below.

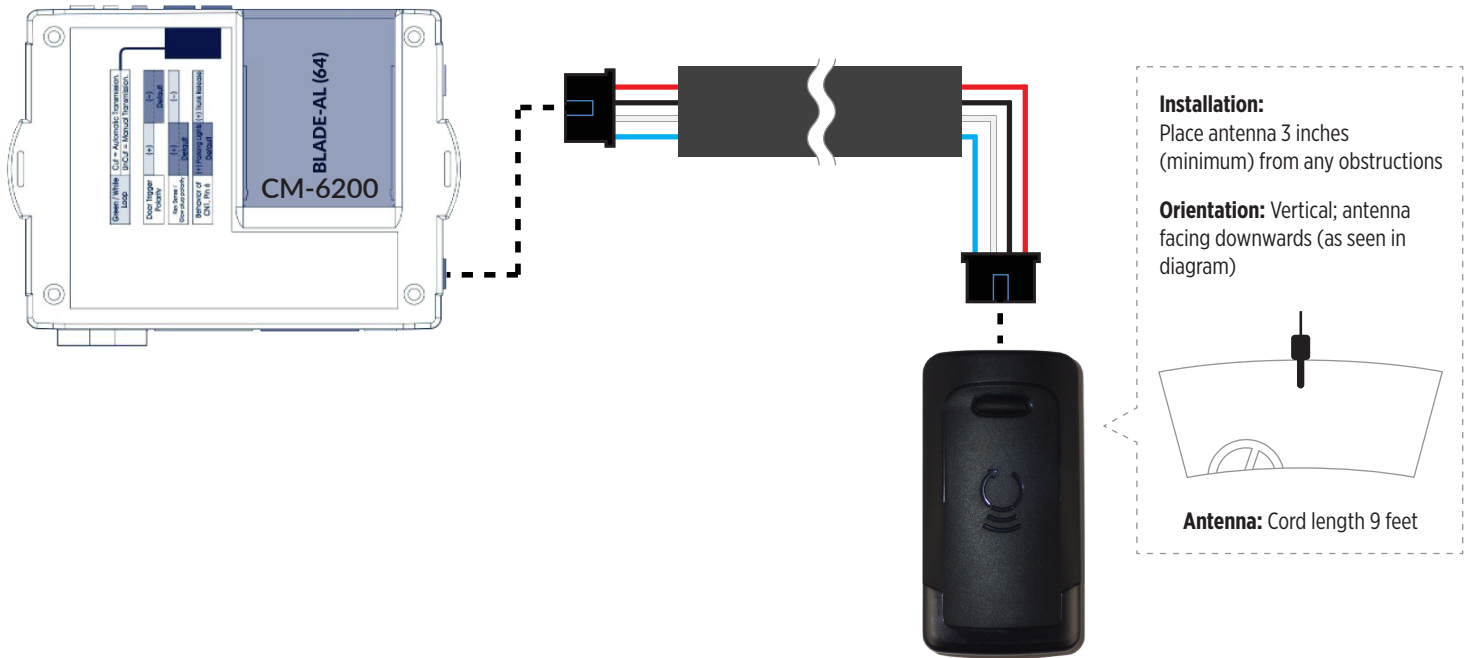

## STEP 5. LEARNING PROCEDURE

5A. AUTO-LEARNING PROCEDURE	5B. MANUAL LEARNING PROCEDURE
<p>NOTE: The transmitters and antenna included in this kit has already been pre-paired together at factory.</p> <ol style="list-style-type: none"> <li><b>PRESS AND HOLD</b> the programming button on the antenna while connecting the 4 pin connector - On power up there will be a quick Red and White LED blink.</li> <li>Then the Red LED will flash slowly, <b>RELEASE</b> the programming button</li> <li>The Red LED will turn solid for 2 seconds.</li> <li>Then the White LED will flash rapidly. This will initiate the Auto-learning procedure to detect which remote starter it's connected to.</li> <li>Once the remote starter model has been detected, the White LED will flash as indicated in the LED FLASH CHART below.</li> <li>If the auto-learning was succesful, proceed to Step 6.</li> </ol>	<ol style="list-style-type: none"> <li><b>PRESS AND HOLD</b> the programming button on the antenna while connecting the 4 pin connector - On power up there will be a quick Red and White LED blink.</li> <li>Then the Red LED will flashes slowly. Keep holding the programming button for a few seconds until the Red LED flashes rapidly, <b>RELEASE</b> the programming button</li> <li>The Red LED will turn solid for 2 seconds.</li> <li>Then the White LED will flash slowly. This will initiate the Manual Learning Procedure.</li> <li><b>Press and Release</b> the programming button on the antenna to make your selection as indicated below.</li> <li>Once the correct selection is made, <b>PRESS AND HOLD</b> the programming button until the White LED turns solid for 2 seconds.</li> </ol>

### LED FLASH CHART

- 1x flash = iDatastart HC - VW
- 2x flashes = Directed
- 3x flashes = Compustar Blade**
- 4x flashes = Fortin - AKX - iDatastart BM, BZ - ADS-AL-CA
- 5x flashes = Unable to detect remote starter model. -- Please proceed to the "Manual Learning Procedure" in step 5B.



## STEP 6. TEST YOUR RF KIT

- a. Test all functions supported by your remote starter.
- b. If remote starter is reacting but the vehicle is not responding to a command, see your remote starter error code for diagnostics.
- c. If no reaction from the remote starter, please check your remote starter configurations or protocol selection.
- d. If it is still not working try programming the transmitters. Go to Step 7 below.

## STEP 7. PROGRAMMING TRANSMITTERS

NOTE: A maximum of 4x aftermarket transmitters can be programmed per system.

- a. Cycle ignition On/Off 5x times. (5x OFF/ON)
- b. The Red LED will turn On in the antenna.
- c. WHILE HOLDING THE TRANSMITTERS CLOSE TO THE ANTENNA (Max 1 foot away) Press and Release the Lock button on every transmitter that must be learned or "F" + Lock for 2nd Car operation.
- d. Cycle the ignition to OFF to exit programming mode.

## RESET PROCEDURE

NOTE: The reset procedure can be done at any time.

- a. PRESS AND HOLD the programming button on the Antenna while connecting the 4 pin connector.
- b. When the Red LED Flashes slowly, RELEASE the programming button.
- c. The Red LED will turn solid for 2 seconds.
- d. Reset completed





## REQUIRED PARTS FOR DBALL 2 INSTALLATION

<p>XTX-2000</p> 	<p>IVU-CAB-4W</p> 	<p>DBALL 2</p> 	<p>HRN-CRF-01</p> 
---	---	---	---

### STEP 1. UPDATE YOUR ANTENNA

Connect your antenna to the ADS Weblink (ADS-USB) to update the antenna firmware to ensure that you have the latest firmware available.

- Go to [www.idatalink.com](http://www.idatalink.com) and click on “Flash your module” (See image #1)
- When your Connected XTX2000 antenna is detected it will offer the latest firmware available for your XTX2000.
- Select the most recent firmware available.
- Click “Flash!” (See image #2)



Image 1



Image 2

### STEP 2. CONFIGURE THE REMOTE STARTER

The XKloader 2 is required to properly configure the DBALL 2 remote starter to accept the Connected RF kit. When flashing the DBALL 2 remote starter, **please follow this procedure in order to configure correctly your remote starter.**

- Go to [www.directechs.com](http://www.directechs.com) and click on “Flash module” (See image #1)
- Run thru the configuration process and make sure to choose “Config for RSR”(See image #2)
- Choose “SmartStart” option. (See image #3)
- Complete the configuration process.
- Click “Flash!” (See image #4)



Image 1

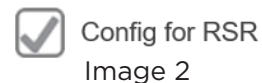

Image 2



Image 3



Image 4

### STEP 3. LEARN THE REMOTE STARTER

**BEFORE CONNECTING YOUR ANTENNA TO THE REMOTE STARTER** the remote starter **MUST** be learned to the vehicle. Please follow the remote starter installation manual on how to learn your remote starter to the vehicle that you are working on.



# CONNECTED INSTALLATION, WIRING & PROGRAMMING GUIDE

## STEP 4. CONNECT

Once the remote starter learning is completed, connect the RF Kit antenna by following the wiring guide as shown below.

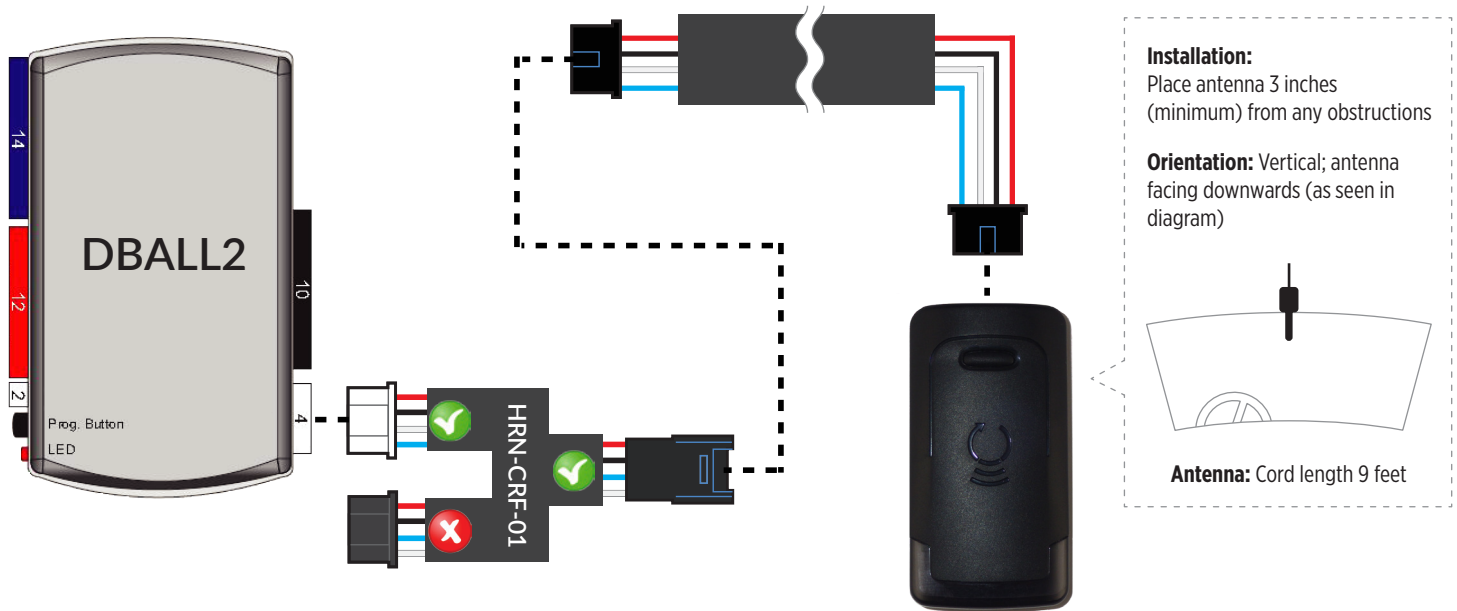

## STEP 5. LEARNING PROCEDURE

5A. AUTO-LEARNING PROCEDURE	5B. MANUAL LEARNING PROCEDURE
<p>NOTE: The transmitters and antenna included in this kit has already been pre-paired together at factory.</p> <ol style="list-style-type: none"> <li><b>PRESS AND HOLD</b> the programming button on the antenna while connecting the 4 pin connector - On power up there will be a quick Red and White LED blink.</li> <li>Then the Red LED will flash slowly, <b>RELEASE</b> the programming button</li> <li>The Red LED will turn solid for 2 seconds.</li> <li>Then the White LED will flash rapidly. This will initiate the Auto-learning procedure to detect which remote starter it's connected to.</li> <li>Once the remote starter model has been detected, the White LED will flash as indicated in the LED FLASH CHART below.</li> <li>If the auto-learning was succesful, proceed to Step 6.</li> </ol>	<ol style="list-style-type: none"> <li><b>PRESS AND HOLD</b> the programming button on the antenna while connecting the 4 pin connector - On power up there will be a quick Red and White LED blink.</li> <li>Then the Red LED will flashes slowly. Keep holding the programming button for a few seconds until the Red LED flashes rapidly, <b>RELEASE</b> the programming button</li> <li>The Red LED will turn solid for 2 seconds.</li> <li>Then the White LED will flash slowly. This will initiate the Manual Learning Procedure.</li> <li><b>Press and Release</b> the programming button on the antenna to make your selection as indicated below.</li> <li>Once the correct selection is made, <b>PRESS AND HOLD</b> the programming button until the White LED turns solid for 2 seconds.</li> </ol>

### LED FLASH CHART

- 1x flash = iDatastart HC - VW
- 2x flashes = Directed**
- 3x flashes = Compustar Blade
- 4x flashes = Fortin - AKX - iDatastart BM, BZ - ADS-AL-CA
- 5x flashes = Unable to detect remote starter model. -- Please proceed to the "Manual Learning Procedure" in step 5B.



## STEP 6. TEST YOUR RF KIT

- a. Test all functions supported by your remote starter.
- b. If remote starter is reacting but the vehicle is not responding to a command, see your remote starter error code for diagnostics.
- c. If no reaction from the remote starter, please check your remote starter configurations or protocol selection.
- d. If it is still not working try programming the transmitters. Go to Step 7 below.

## STEP 7. PROGRAMMING TRANSMITTERS

NOTE: A maximum of 4x aftermarket transmitters can be programmed per system.

- a. Cycle ignition On/Off 5x times. (5x OFF/ON)
- b. The Red LED will turn On in the antenna.
- c. WHILE HOLDING THE TRANSMITTERS CLOSE TO THE ANTENNA (Max 1 foot away) Press and Release the Lock button on every transmitter that must be learned or "F" + Lock for 2nd Car operation.
- d. Cycle the ignition to OFF to exit programming mode.

## RESET PROCEDURE

NOTE: The reset procedure can be done at any time.

- a. PRESS AND HOLD the programming button on the Antenna while connecting the 4 pin connector.
- b. When the Red LED Flashes slowly, RELEASE the programming button.
- c. The Red LED will turn solid for 2 seconds.
- d. Reset completed





## REQUIRED PARTS FOR 4X10 - 5X10 INSTALLATION

<p>XTX-2000</p> 	<p>IVU-CAB-4W</p> 	<p>4X10 - 5X10</p> 	<p>HRN-CRF-01</p> 
---	---	---	---

### STEP 1. UPDATE YOUR ANTENNA

Connect your antenna to the ADS Weblink (ADS-USB) to update the antenna firmware to ensure that you have the latest firmware available.

- Go to [www.idatalink.com](http://www.idatalink.com) and click on “Flash your module” (See image #1)
- When your Connected XTX2000 antenna is detected it will offer the latest firmware available for your XTX2000.
- Select the most recent firmware available.
- Click “Flash!” (See image #2)



Image 1



Image 2

### STEP 2. CONFIGURE THE REMOTE STARTER

The XKloader 2 is required to properly configure the 4X10 - 5X10 remote starter to accept the Connected RF kit. When flashing the 4X10 - 5X10 remote starter, **please follow this procedure in order to configure correctly your remote starter.**

- Go to [www.directechs.com](http://www.directechs.com) and click on “Flash module” (See image #1)
- Run thru the configuration process and make sure to choose “Remote Start”(See image #2)
- Choose “SmartStart” option. (See image #3)
- Complete the configuration process.
- Click “Flash!” (See image #4)



Image 1



Remote Start

Image 2



Image 3



Image 4

### STEP 3. LEARN THE REMOTE STARTER

**BEFORE CONNECTING YOUR ANTENNA TO THE REMOTE STARTER** the remote starter **MUST** be learned to the vehicle. Please follow the remote starter installation manual on how to learn your remote starter to the vehicle that you are working on.





# CONNECTED INSTALLATION, WIRING & PROGRAMMING GUIDE

## STEP 4. CONNECT

Once the remote starter learning is completed, connect the RF Kit antenna by following the wiring guide as shown below.

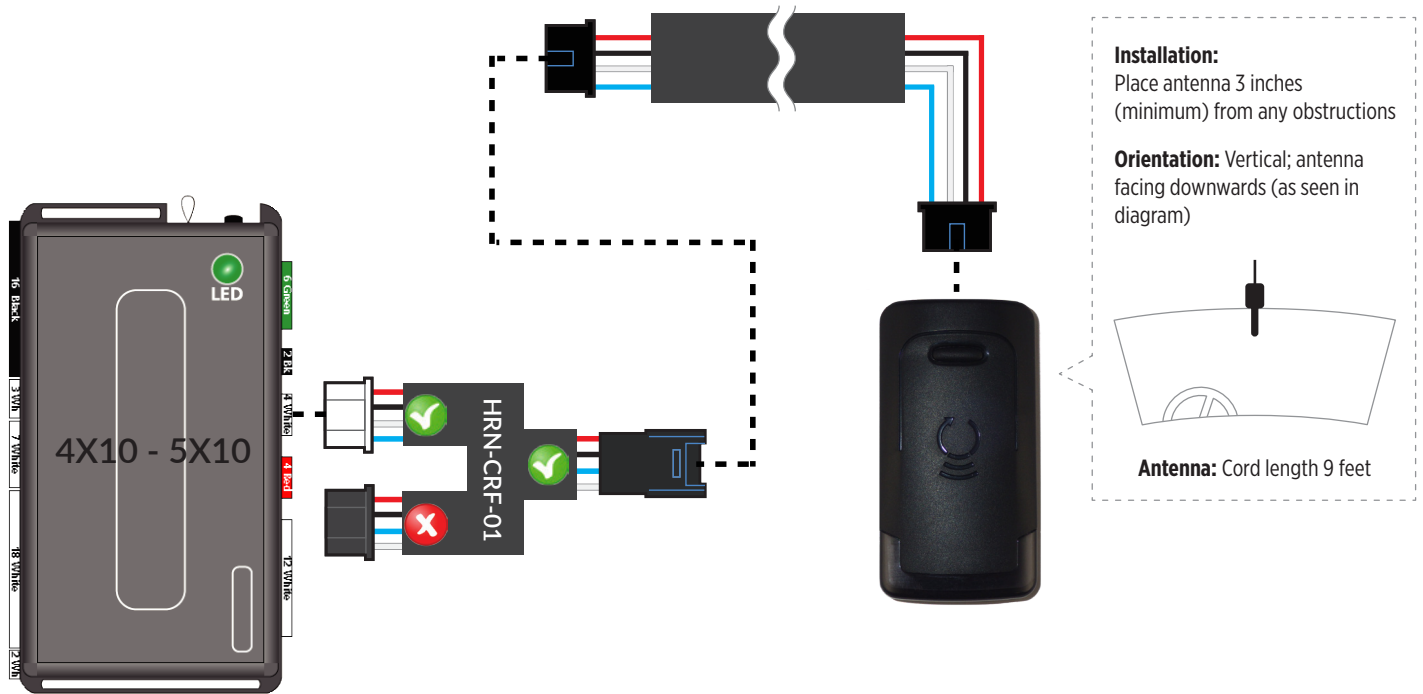

## STEP 5. LEARNING PROCEDURE

5A. AUTO-LEARNING PROCEDURE	5B. MANUAL LEARNING PROCEDURE
<p>NOTE: The transmitters and antenna included in this kit has already been pre-paired together at factory.</p> <ol style="list-style-type: none"> <li><b>PRESS AND HOLD</b> the programming button on the antenna while connecting the 4 pin connector - On power up there will be a quick Red and White LED blink.</li> <li>Then the Red LED will flash slowly, <b>RELEASE</b> the programming button</li> <li>The Red LED will turn solid for 2 seconds.</li> <li>Then the White LED will flash rapidly. This will initiate the Auto-learning procedure to detect which remote starter it's connected to.</li> <li>Once the remote starter model has been detected, the White LED will flash as indicated in the LED FLASH CHART below.</li> <li>If the auto-learning was succesful, proceed to Step 6.</li> </ol>	<ol style="list-style-type: none"> <li><b>PRESS AND HOLD</b> the programming button on the antenna while connecting the 4 pin connector - On power up there will be a quick Red and White LED blink.</li> <li>Then the Red LED will flashes slowly. Keep holding the programming button for a few seconds until the Red LED flashes rapidly, <b>RELEASE</b> the programming button</li> <li>The Red LED will turn solid for 2 seconds.</li> <li>Then the White LED will flash slowly. This will initiate the Manual Learning Procedure.</li> <li><b>Press and Release</b> the programming button on the antenna to make your selection as indicated below.</li> <li>Once the correct selection is made, <b>PRESS AND HOLD</b> the programming button until the White LED turns solid for 2 seconds.</li> </ol>

### LED FLASH CHART

- 1x flash = iDatastart HC - VW
- 2x flashes = Directed**
- 3x flashes = Compustar Blade
- 4x flashes = Fortin - AKX - iDatastart BM, BZ - ADS-AL-CA
- 5x flashes = Unable to detect remote starter model. -- Please proceed to the "Manual Learning Procedure" in step 5B.



## STEP 6. TEST YOUR RF KIT

- a. Test all functions supported by your remote starter.
- b. If remote starter is reacting but the vehicle is not responding to a command, see your remote starter error code for diagnostics.
- c. If no reaction from the remote starter, please check your remote starter configurations or protocol selection.
- d. If it is still not working try programming the transmitters. Go to Step 7 below.

## STEP 7. PROGRAMMING TRANSMITTERS

NOTE: A maximum of 4x aftermarket transmitters can be programmed per system.

- a. Cycle ignition On/Off 5x times. (5x OFF/ON)
- b. The Red LED will turn On in the antenna.
- c. WHILE HOLDING THE TRANSMITTERS CLOSE TO THE ANTENNA (Max 1 foot away) Press and Release the Lock button on every transmitter that must be learned or "F" + Lock for 2nd Car operation.
- d. Cycle the ignition to OFF to exit programming mode.

## RESET PROCEDURE





NOTE: The reset procedure can be done at any time.

- a. PRESS AND HOLD the programming button on the Antenna while connecting the 4 pin connector.
- b. When the Red LED Flashes slowly, RELEASE the programming button.
- c. The Red LED will turn solid for 2 seconds.
- d. Reset completed





## REQUIRED PARTS FOR EVO-ALL INSTALLATION

<p>XTX-2000</p> 	<p>IVU-CAB-4W</p> 	<p>EVO-ALL</p> 	<p>HRN-CRF-01</p> 
---	---	---	---

### STEP 1. UPDATE YOUR ANTENNA

Connect your antenna to the ADS Weblink (ADS-USB) to update the antenna firmware to ensure that you have the latest firmware available.

- Go to [www.idatalink.com](http://www.idatalink.com) and click on “Flash your module” (See image #1)
- When your Connected XTX2000 antenna is detected it will offer the latest firmware available for your XTX2000.
- Select the most recent firmware available.
- Click “Flash!” (See image #2)



Image 1



Image 2

### STEP 2. CONFIGURE THE REMOTE STARTER

The FlashLink Updater 2 is required to properly configure the EVO-ALL remote starter to accept the Connected RF kit. When flashing the EVO-ALL remote starter, **please follow this procedure in order to configure correctly your remote starter.**

- Open the Flash Link Manager ” (See image #1)
- Choose vehicle Make Model Year (See image #2)
- Select the “Option Tab” and then turn On feature: **C1 and D1** (See image #3)
- Then scroll down and turn On feature: **H2** (See image #4)
- Click “Save Options” (See image #5)
- Click “Flash!” (See image #6)



Image 1

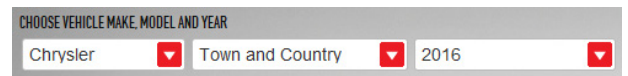

Image 2

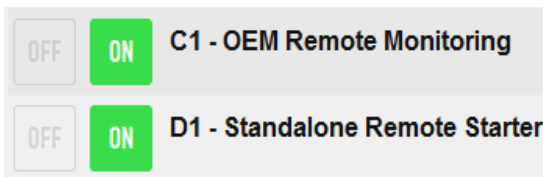

Image 3

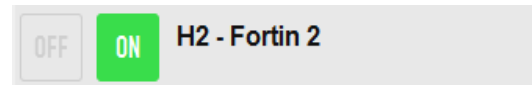

Image 4



Image 5



Image 6

### STEP 3. LEARN THE REMOTE STARTER

**BEFORE CONNECTING YOUR ANTENNA TO THE REMOTE STARTER** the remote starter **MUST** be learned to the vehicle. Please follow the remote starter installation manual on how to learn your remote starter to the vehicle that you are working on.



# CONNECTED INSTALLATION, WIRING & PROGRAMMING GUIDE

## STEP 4. CONNECT

Once the remote starter learning is completed, connect the RF Kit antenna by following the wiring guide as shown below.

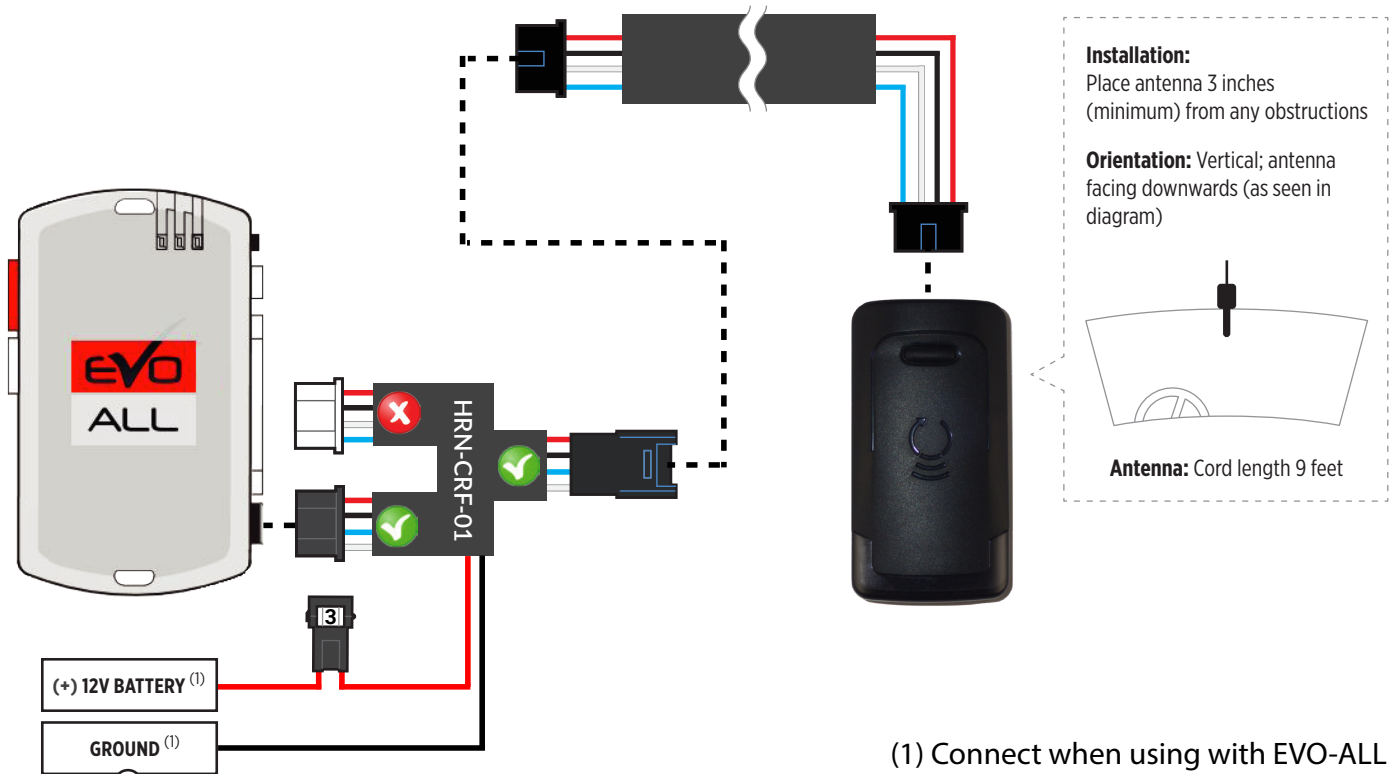

## STEP 5. LEARNING PROCEDURE

5A. AUTO-LEARNING PROCEDURE	5B. MANUAL LEARNING PROCEDURE
<p>NOTE: The transmitters and antenna included in this kit has already been pre-paired together at factory.</p> <ol style="list-style-type: none"> <li><b>PRESS AND HOLD</b> the programming button on the antenna while connecting the 4 pin connector - On power up there will be a quick Red and White LED blink.</li> <li>Then the Red LED will flash slowly, <b>RELEASE</b> the programming button</li> <li>The Red LED will turn solid for 2 seconds.</li> <li>Then the White LED will flash rapidly. This will initiate the Auto-learning procedure to detect which remote starter it's connected to.</li> <li>Once the remote starter model has been detected, the White LED will flash as indicated in the LED FLASH CHART below.</li> <li>If the auto-learning was succesful, proceed to Step 6.</li> </ol>	<ol style="list-style-type: none"> <li><b>PRESS AND HOLD</b> the programming button on the antenna while connecting the 4 pin connector - On power up there will be a quick Red and White LED blink.</li> <li>Then the Red LED will flashes slowly. Keep holding the programming button for a few seconds until the Red LED flashes rapidly, <b>RELEASE</b> the programming button</li> <li>The Red LED will turn solid for 2 seconds.</li> <li>Then the White LED will flash slowly. This will initiate the Manual Learning Procedure.</li> <li><b>Press and Release</b> the programming button on the antenna to make your selection as indicated below.</li> <li>Once the correct selection is made, <b>PRESS AND HOLD</b> the programming button until the White LED turns solid for 2 seconds.</li> </ol>

### LED FLASH CHART

- 1x flash = iDatastart HC - VW
- 2x flashes = Directed
- 3x flashes = Compustar Blade
- 4x flashes = Fortin - AKX - iDatastart BM, BZ - ADS-AL-CA**
- 5x flashes = Unable to detect remote starter model. -- Please proceed to the "Manual Learning Procedure" in step 5B.



## STEP 6. PROGRAMMING TRANSMITTERS

NOTE: A maximum of 4x aftermarket transmitters can be programmed per system.

- a. Disconnect the Black 4 pin power connector from the Evo-All.
- b. Press and Hold the Programming button on the Evo-All while plugging back the Black 4 pin connector.
- c. The LED's on the Evo-All will begin to cycle. Keep pressing the programming button until the RED and BLUE LED's are On.
- d. Release the programming button.
- e. Press and Hold the programming button again for 5 seconds. The BLUE and RED LED's will blink once.
- f. Release the programming button.
- g. Cycle the ignition to the ON position.
- h. The RED, YELLOW and BLUE LED's will be ON and the Red LED will turn On in the antenna.
- i. WHILE HOLDING THE TRANSMITTERS CLOSE TO THE ANTENNA (Max 1 foot away) Press and Release the Lock button on every transmitter that must be learned or "F" + Lock for 2nd Car operation.
- j. Cycle the vehicle's ignition to the OFF position to Exit Transmitter programming and EVO-ALL programming.

## STEP 7. TEST YOUR RF KIT

- a. Test all functions supported by your remote starter.
- b. If remote starter is reacting but the vehicle is not responding to a command, see your remote starter error code for diagnostics.
- c. If no reaction from the remote starter, please check your remote starter configurations or protocol selection.
- d. If it is still not working try programming the transmitters. Go to Step 6 above.

## RESET PROCEDURE





NOTE: The reset procedure can be done at any time.

- a. PRESS AND HOLD the programming button on the Antenna while connecting the 4 pin connector.
- b. When the Red LED Flashes slowly, RELEASE the programming button.
- c. The Red LED will turn solid for 2 seconds.
- d. Reset completed programming transmitters





## REQUIRED PARTS FOR EVO-ONE INSTALLATION

<p>XTX-2000</p> 	<p>IVU-CAB-4W</p> 	<p>EVO-ONE</p> 	<p>HRN-CRF-01</p> 
---	---	---	---

### STEP 1. UPDATE YOUR ANTENNA

Connect your antenna to the ADS Weblink (ADS-USB) to update the antenna firmware to ensure that you have the latest firmware available.

- Go to [www.idatalink.com](http://www.idatalink.com) and click on “Flash your module” (See image #1)
- When your Connected XTX2000 antenna is detected it will offer the latest firmware available for your XTX2000.
- Select the most recent firmware available.
- Click “Flash!” (See image #2)



Image 1



Image 2

### STEP 2. CONFIGURE THE REMOTE STARTER

The FlashLink Updater 2 is required to properly configure the EVO-ONE remote starter to accept the Connected RF kit. When flashing the EVO-ONE remote starter, **please follow this procedure in order to configure correctly your remote starter.**

- Open the Flash Link Manager ” (See image #1)
- Click on the “Toggle” button at the bottom right of the screen (See image #2)
- From the top menu choose “Configuration” and then “Unit Options” (See image #3)
- In the first option “RF Kits Compatible” check the box next to “Fortin 2” (See image #4)
- Click “Save” at the top of the Unit option page (See image #5)



Image 1



Image 2

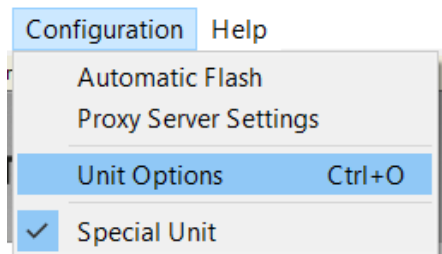

Image 3

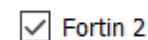

Image 4



Image 5

### STEP 3. LEARN THE REMOTE STARTER

**BEFORE CONNECTING YOUR ANTENNA TO THE REMOTE STARTER** the remote starter **MUST** be learned to the vehicle. Please follow the remote starter installation manual on how to learn your remote starter to the vehicle that you are working on.





# CONNECTED INSTALLATION, WIRING & PROGRAMMING GUIDE

## STEP 4. CONNECT

Once the remote starter learning is completed, connect the RF Kit antenna by following the wiring guide as shown below.

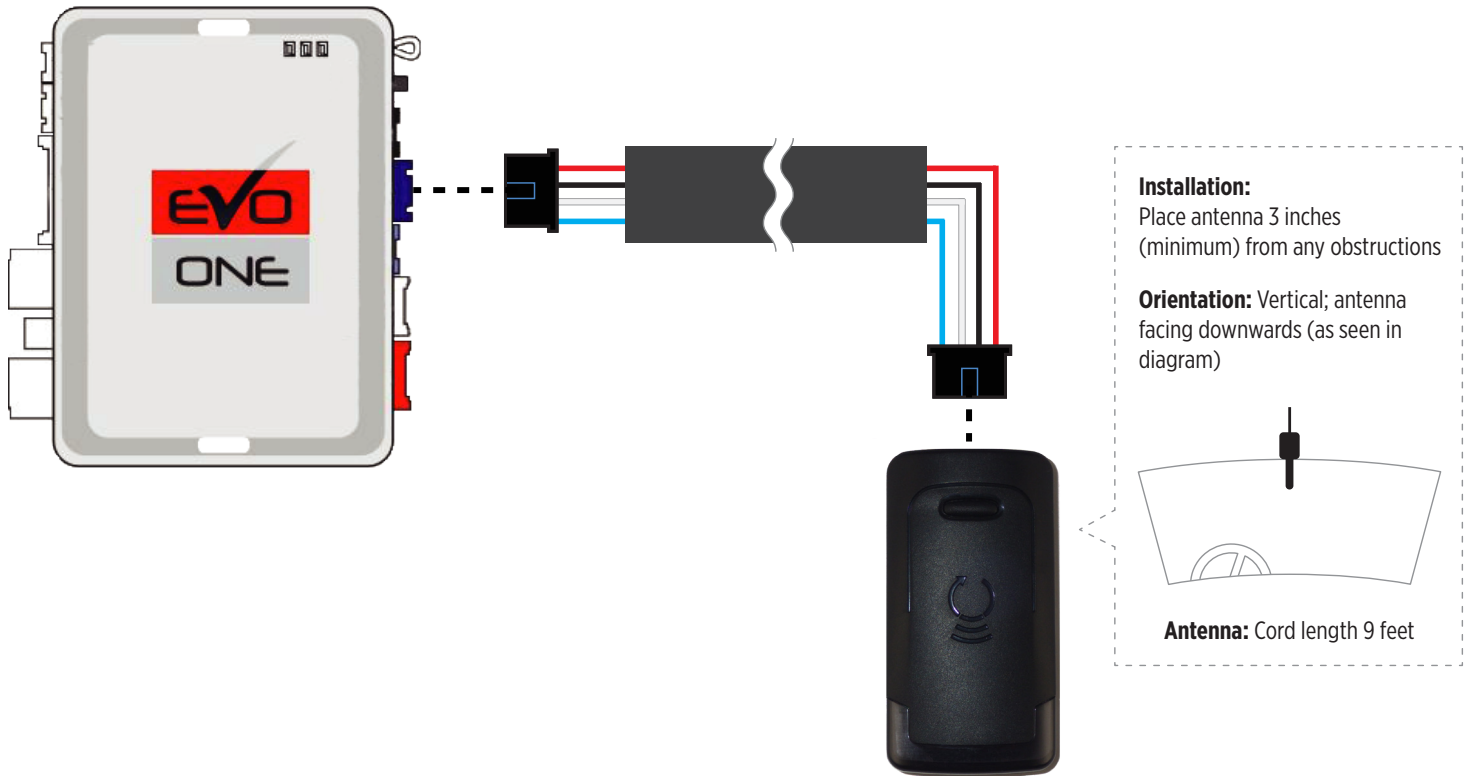

## STEP 5. LEARNING PROCEDURE

5A. AUTO-LEARNING PROCEDURE	5B. MANUAL LEARNING PROCEDURE
<p>NOTE: The transmitters and antenna included in this kit has already been pre-paired together at factory.</p> <ol style="list-style-type: none"> <li><b>PRESS AND HOLD</b> the programming button on the antenna while connecting the 4 pin connector - On power up there will be a quick Red and White LED blink.</li> <li>Then the Red LED will flash slowly, <b>RELEASE</b> the programming button</li> <li>The Red LED will turn solid for 2 seconds.</li> <li>Then the White LED will flash rapidly. This will initiate the Auto-learning procedure to detect which remote starter it's connected to.</li> <li>Once the remote starter model has been detected, the White LED will flash as indicated in the LED FLASH CHART below.</li> <li>If the auto-learning was succesful, proceed to Step 6.</li> </ol>	<ol style="list-style-type: none"> <li><b>PRESS AND HOLD</b> the programming button on the antenna while connecting the 4 pin connector - On power up there will be a quick Red and White LED blink.</li> <li>Then the Red LED will flashes slowly. Keep holding the programming button for a few seconds until the Red LED flashes rapidly, <b>RELEASE</b> the programming button</li> <li>The Red LED will turn solid for 2 seconds.</li> <li>Then the White LED will flash slowly. This will initiate the Manual Learning Procedure.</li> <li><b>Press and Release</b> the programming button on the antenna to make your selection as indicated below.</li> <li>Once the correct selection is made, <b>PRESS AND HOLD</b> the programming button until the White LED turns solid for 2 seconds.</li> </ol>

### LED FLASH CHART

- 1x flash = iDatastart HC - VW
- 2x flashes = Directed
- 3x flashes = Compustar Blade
- 4x flashes = Fortin - AKX - iDatastart BM, BZ - ADS-AL-CA**
- 5x flashes = Unable to detect remote starter model. -- Please proceed to the "Manual Learning Procedure" in step 5B.



## STEP 6. PROGRAMMING TRANSMITTERS

NOTE: A maximum of 4x aftermarket transmitters can be programmed per system.

- a. Cycle the ignition to the ON position.
- b. The YELLOW LED on top of the EVO-ONE should come ON.
- c. Press and Hold the EVO-ONE push button for 5 seconds.
- d. The parking lights and the RED LED on the side of the EVO-ONE will turn ON.
- e. Release the push button.
- f. Press and Release the push button 5x times. Everytime the push button is pressed the parking lights and the RED Led on the side of the EVO-ONE will blink.
- g. Then Press and Release the Brake pedal.
- h. The Red LED will turn On in the antenna.
- i. WHILE HOLDING THE TRANSMITTERS CLOSE TO THE ANTENNA (Max 1 foot away) Press and Release the Lock button on every transmitter that must be learned or "F" + Lock for 2nd Car operation.
- j. Cycle the vehicle's ignition to the OFF position to Exit Transmitter programming and EVO-ONE programming.

## STEP 7. TEST YOUR RF KIT

- a. Test all functions supported by your remote starter.
- b. If remote starter is reacting but the vehicle is not responding to a command, see your remote starter error code for diagnostics.
- c. If no reaction from the remote starter, please check your remote starter configurations or protocol selection.
- d. If it is still not working try programming the transmitters. Go to Step 6 above.

## RESET PROCEDURE

NOTE: The reset procedure can be done at any time.

- a. PRESS AND HOLD the programming button on the Antenna while connecting the 4 pin connector.
- b. When the Red LED Flashes slowly, RELEASE the programming button.
- c. The Red LED will turn solid for 2 seconds.
- d. Reset completedprogramming transmitters





CONNECTED